

D171CT Compression Ended T-Handle Ball Valve D171CLS Compression Ended Lockshield Ball Valve

Crane D171 Ball Valves are light, compact units which are easy to install and operate, yet their robust construction ensures long, trouble free service life.

In addition the D171CT and D171CLS are WRAS approved.

Materials

Part	Material	Sizes
Body	Bronze BSEN1982 CC491K	All
Seat Retainer	Bronze BSEN1982 CC491K	15mm - 28mm
Seat Retainer	Bronze BSEN1982 CC491K	35mm - 54mm
Ball	DZR Brass BSEN12165 CW602N	All
Seat	PTFE	All
Stem	DZR Brass BSEN12164 CW602N	All
Packing	PTFE	All
Gland Nut	Brass BSEN12164 CW617N	All
'T' Handle	Aluminium	D171CT
Screw	Steel (Zinc Plated)	D171CT
Compression Olive	DZR Brass BSEN12164 CW602N	All
Compression Nut	DZR Brass BSEN12165 CW602N	All
Lockshield	Brass BS2872	D171CLS
Lockshield Cover	Nylon 6	D171CLS



D171CT



D171CLS

Dimensional Drawing

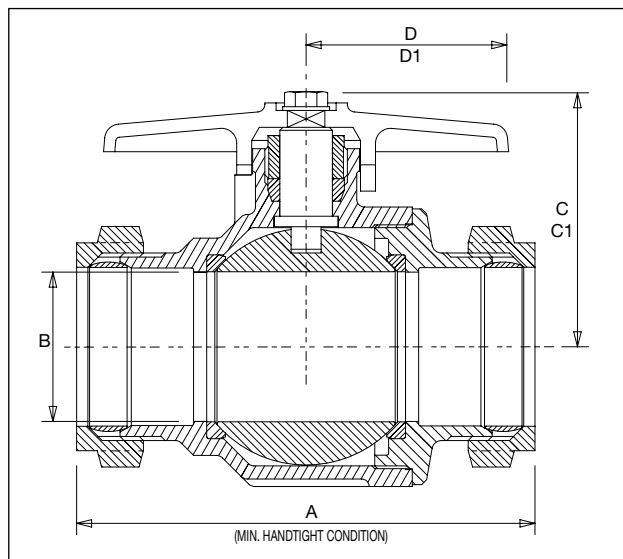

Dimensions and Weights

Size	Weight (kg)	A (mm)	B (mm)	C (mm)	C1 (mm) D171CLS	D (mm)	D1 (mm) D171CLS
15mm	0.25	80	15	42	48	55	29
22mm	0.47	84	20	43	51	55	36
28mm	0.73	95	25	53	58	83	39

Pressure/Temperature Ratings

Compression

Temperature °C	2 - 30	65	120
Pressure (bar)	16	10	5

Intermediate pressure ratings shall be determined by interpolation

Pressure Rating: PN16

UK End Connection: Compression Ends to BSEN 1057 table 4

Operator: T-Handle / Allen Key

Specification:

End Entry, Quarter Turn, Tight Shut-Off

This valve is intended for Group 2 liquids as defined by the Pressure Equipment Directive 97/23/EC.