

D171T T-Handle Bronze Ball Valve
D171LS Lockshield Bronze Ball Valve

Crane D171 Ball Valves are light, compact units which are easy to install and operate, yet their robust construction ensures long, trouble free service life.

In addition the D171T and D171LS are WRAS approved.

Materials

Part	Material	Sizes
Body	Bronze BSEN1982 CC491K	All
Seat Retainer	Bronze BSEN1982 CC491K	All
Ball	DZR Brass BSEN12165 CW602N	All
Seats	PTFE	All
Stem	DZR Brass BSEN12164 CW602N	All
Packing	PTFE	All
Gland Nut	DZR Brass BSEN12164 CW602N	All
'T' Handle	Aluminium	D171T
Screw	Steel (Zinc Plated)	D171T
Lockshield Cap	Brass BSEN12164 CW617N	D171LS
Screw	Mild Steel	D171LS
Lockshield Cover	Nylon 6	D171LS



D171T



D171LS

Dimensional Drawing

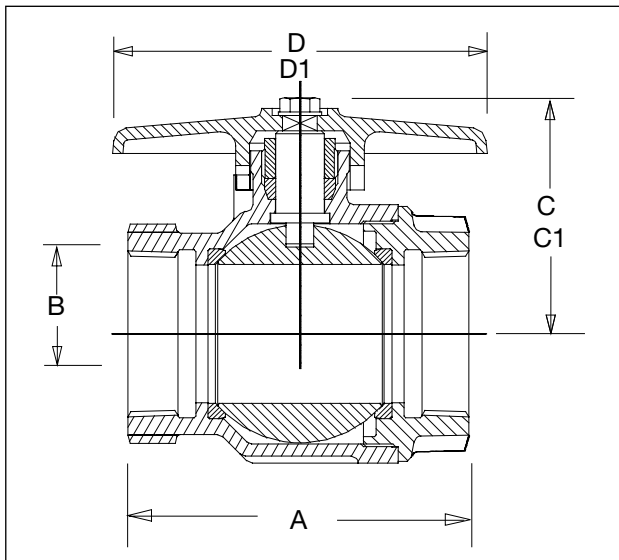

Dimensions and Weights

Size	Weight (kg)	A (mm)	B (mm)	C (mm)	C1 (mm)	D (mm)	D1 (mm)
3/8"	0.13	46	10	31	-	38	-
1/2"	0.2	57	15	40	48	55	36
3/4"	0.41	67	20	43	51	55	36
1"	0.64	77	25	53	58	83	39
1.1/4"	1.07	91	32	58	63	83	39
1.1/2"	1.57	103	40	73	76	108	49
2"	2.83	122	50	80	84	108	49

Pressure Rating: PN25

UK End Connection: BSEN10226 formerly BS21 Taper

US End Connection: ANSI B1.20.1

Operator: T-Handle / Allen key

Specification:

End Entry, Quarter Turn, Tight Shut-Off

PTFE seats and stem seal, WRAS listed.

This valve is not suitable for use on group 1 gasses or unstable fluids, as defined by the Pressure Equipment Directive 97/23/EC.

Temperature operating range: -10 to 186°C.