

D71

D71

Globe Valve

PN32

Features & Benefits

- Crane bronze globe valves are highly efficient for throttling because seat and disc designs provide flow characteristics with proportionate relationships between valve lift and flow rate.



GENERAL VALVES

Materials

NO.	PART	MATERIAL	SIZES
1	Body	Bronze BS EN 1982 CC491K	-
2	Bonnet	Sil. Al. Bronze BS EN 12163 CW301G	1/8 - 3/8
2	Bonnet	Brass BS EN 12164 CW614N	3/4
3	Stem	Sil. Al. Bronze BS EN 12163 CW301G	-
4	Packing*	Asbestos Free	-
5	Gland	Brass BS EN 12164 CW614N	-
6	Packing Nut	Brass BS EN 12164 CW614N	-
7	Handwheel	Aluminium	-
8	Handwheel Nut	Brass BS EN 12164 CW614N	-
9	Identity Plate	Aluminium	-

*Recommended spares

Dimensions & Weights

SIZE (inch)	WEIGHT (kg)	A (mm)	B (mm)	C (mm)
1/8	0.13	29	74	44
1/4	0.15	39	73	44
3/8	0.21	45	77	44
1/2	0.29	51	91	52
3/4	0.46	58	104	65

Dimensional Drawing

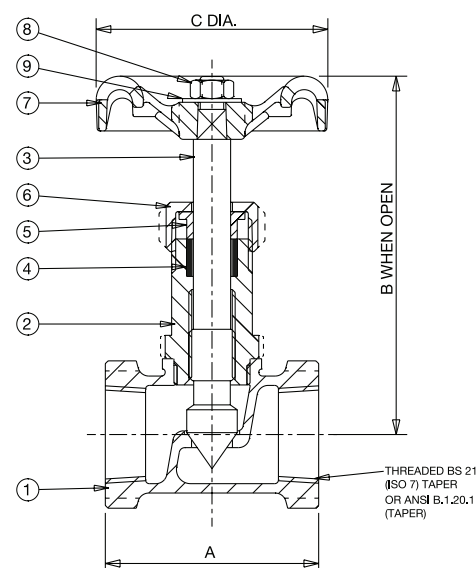

PRESSURE RATING: PN32

TEMPERATURE OPERATING RANGE: -10 to 100°C

END CONNECTION: Threaded BS 21 or ANSI B1.20.1

SPECIFICATION: Valve are manufactured in accordance with BS 5154 PN32 for Series B ratings. The needle disk is an integral part of the stem, and body seat is integral.

Valid as of 290719

Every effort has been made to ensure that the information contained in this publication is accurate at the time of publishing. Crane Ltd assumes no responsibility or liability for typographical errors or omissions or for any misinterpretation of the information within the publication and reserves the right to change without notice.