

F84

F84

Cast Iron Gate Valve Rising Stem

Class 125

Features & Benefits

- Crane cast iron gate valves offer the ultimate in dependable service wherever minimum pressure drop is important
- Each valve is manufactured in accordance with BS 5150: 1990
- Rising stem gives visual indication of valve open position

Materials

PART	MATERIAL	SIZES
Body	Cast Iron BS EN 1561 GJL-250	All
Bonnet	Cast Iron BS EN 1561 GJL-250	All
Disc	Bronze BS EN 1982 CC491K	2 - 4
Disc	Cast Iron BS EN 1561 GJL-250	5 - 12
Stem	Brass BS EN 12164: CW603N	2 - 10
Stem	Stainless Steel BS EN 10088-3 1.4006 (SS410) / Brass BS EN 12164: CW603N	12
Body Seat Ring	Bronze BS EN 1982 CC491K	All
Disc Ring	Bronze BS EN 1982 CC481K	5 - 12
Yoke	Cast Iron BS EN 1561 GJL-250	5 - 12
Yoke Hub Bolts/Nuts	Steel BS 4190 Gr.4.6/4	5 - 12
Yoke Pad Bolts/Nuts	Steel BS 4190 Gr.4.6/4	5 - 12
Yokesleeve	Manganese Bronze ASTM B584-C86400	2 - 4
Yokesleeve	Bronze BS EN 1982 CC491K	5 - 12
Yokesleeve Ret'g Nut	Malleable Iron BS EN 1562 GJMB-300-6	2 - 4
Yokesleeve Nut	Malleable Iron BS EN 1562 GJMB-300-6	2 - 4
Yokesleeve Nut	Ductile Iron ASTM A536 65-45-12	5 - 12
Gland	Malleable Iron BS EN 1562 GJMB-300-6	2 - 4
Gland	Cast Iron BS EN 1561 GJL-250	5 - 12
Gland Flange	Ductile Iron ASTM A536 65-45-12	5 - 12
Packing	Asbestos Free	All
Gasket	Asbestos Free	All
Handwheel	Malleable Iron BS EN 1562 GJMB-300-6	All
Body Plate	Aluminium	All

Dimensions & Weights

SIZE (inch)	WEIGHT (kg)	A (mm)	B (mm)	H (mm)
2	21.5	178	399	203
2½	24.8	190	432	203
3	29.5	203	469	203
4	42.7	229	566	229
5	72.3	254	714	305
6	88.1	267	813	305
8	140	292	1013	356
10	225	330	1257	406
12	314	356	1454	457



Dimensional Drawing

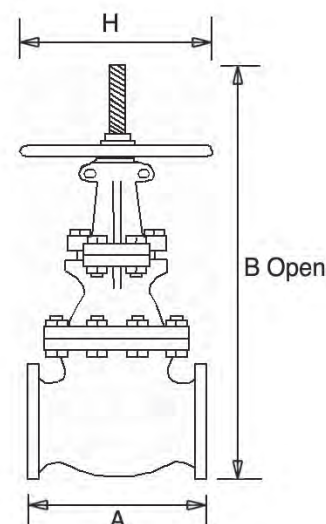

Pressure/Temperature Ratings

TEMPERATURE (°C)	-10 to 65	230
PRESSURE (BAR)	13.8	8.6

Intermediate pressure ratings shall be determined by interpolation.

PRESSURE RATING: Class 125

TEMPERATURE OPERATING RANGE: -10 to 230°C

US END CONNECTION: ANSI Flanged

OPERATOR: Handwheel.

Gate valves are best for services that require infrequent valve operation, and where the disc is kept either fully opened or fully closed. They are not practical for throttling.

SPECIFICATION: Generally compliant with MSS.SP-70: 1998. End flanges conform to BS 1560 Section 3.2/ANSI B16.1. Class 125 with flat face and are normally supplied drilled. Wedge Disc, Rising Stem, Outside Screw and Yoke.

This valve is not suitable for use on group 1 gases or unstable fluids, as defined by the Pressure Equipment Directive 2014/68/EU.*

Valves tested in accordance with BS EN 12266-1: 2003.

AVAILABLE OPTIONS: Flanges Undrilled.

* See page 159 for more information