

# D255C

Bronze Gate Valve with Lockshield  
Non rising stem



PN16

D255C

GENERAL VALVES



## Features & Benefits

- Robust and high quality bronze body with integral seating surfaces
- Offers the ultimate in dependable service wherever minimum pressure drop is important
- WRAS approved for use with wholesome (potable) water
- Inside screw pattern with non-rising stem

## Materials

PART	MATERIAL
Body	Bronze BS EN 1982 CC491K
Bonnet	Bronze BS EN 1982 CC491K
Stem	DZR Brass BS EN 12164 CW602N
Disc	Bronze BS EN 1982 CC491K
Stem Retainer	DZR Brass BS EN 12164 CW602N
Packing Ring	Asbestos Free
Gland (28-54 only)	Brass BS EN 12164 CW614N
Lockshield	Brass BS EN 12164 CW614N
Compression Olive	Brass BS EN 12449:1999 CW505L OR CW507L
Compression Nut	Brass BS EN 12165 CW617N

## Dimensions & Weights

SIZE (mm)	WEIGHT (kg)	A (mm)	B (mm)	D (mm)
15	0.34	69	78	26.5
22	0.50	75	90	23.5
28	0.70	86	110	25.5
35	0.95	100	115	30.5
42	1.45	111	136	34.5
54	2.50	133	160	37

## Dimensional Drawing

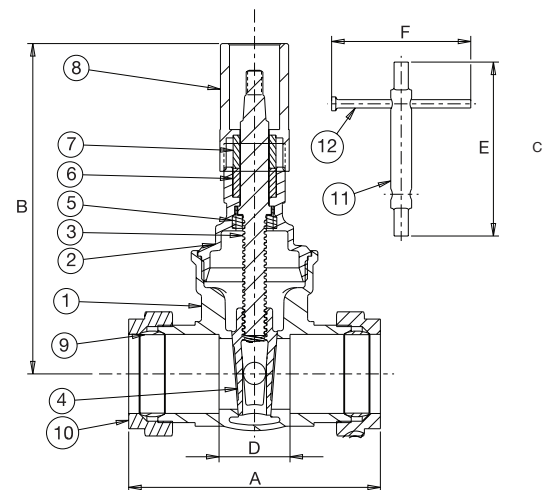

## Pressure/Temperature Ratings

TEMPERATURE (°C)	-10 to 30	40	50	65	
PRESSURE (BAR)	16.0	14.3	12.6	10.0	
TEMPERATURE (°C)	80	90	100	110	120
PRESSURE (BAR)	8.7	7.8	6.9	6.0	5.0

Intermediate pressure ratings shall be determined by interpolation.

WRAS approved -10 to 99°C

**PRESSURE RATING:** PN16

**UK END CONNECTION:**

Compression ends to  
BS EN 1057:2006: Half hard R250

**OPERATOR:** Lockshield.

Gate valves are best for services that require infrequent valve operation, and where the disc is kept either fully opened or fully closed. They are not practical for throttling.

**SPECIFICATION:** Valves are manufactured in accordance with BS EN 12288: 2010 (formerly BS 5154) PN16 for Series B ratings, but are limited to the pressure/ temperature ratings detailed in BS EN 1057: 2006 for compression end fittings.

This valves is suitable for use on Group 2 Gas, Group 1 and Group 2 Liquids as defined by Pressure Equipment Directive 2014/68/EU, and Pressure Equipment (Safety) Regulations 2016, as amended.\*

Not suitable for use on Group 1 Gases or unstable liquids.

**AVAILABLE OPTIONS:** P100 and P102 Lockshield Keys

\*see Quality Assurance page for more information